



# HA - 280 PRO v3 INSTALLATION MANUAL



Manufacturer:  
COMMERCIAL ELECTRONICS CO. LTD  
264 HAYDONS ROAD, WIMBLEDON, LONDON SW19 8TT, UK

TEL: +44 020 8404 7105 FAX: +44 020 8404 7104  
<http://www.hawkcaralarm.com> e-mail: [info@hawkcaralarm.com](mailto:info@hawkcaralarm.com)

**THIS INSTRUCTION MANUAL IS IMPORTANT.  
PLEASE READ IT BEFORE INSTALLING THE UNIT.**

# Contents

Installation points to remember, locations for the siren.....	3
Locations for the control box, locations for the status LED, locations for the Hawkguard shock sensor.....	4
Locations for the Hawkguard ultra sonic sensors, locations for the immobiliser relay, obtaining constant 12 volts.....	5
Finding the 12 volt switched ignition wire, how to find starter wires 12 volts only in crank position.....	6
Finding the door pin switch circuit, making your wiring connections.....	7
Primary harness wire connection guide C1-12 pin connector.....	8
Secondary harness wire connection guide 6 pin connector - C2, immobiliser relay connection guide.....	9
Wiring diagram.....	10
Siren connection guide, jumpers setup.....	12
Central locking technical diagrams.....	13
Bonnet and door protection, interior light supervision relays, boot release configurations.....	17

## Installation points to remember

This product represents many years of research and development. It is very sophisticated and should be installed by experienced security installers only. Please do not attempt installation of this product without reading this guide. The system has been designed to provide the ultimate in security, coupled with limitless convenience and expansion options.

Do not disconnect the battery if the vehicle has an anti-theft coded radio. If equipped with an air bag, avoid disconnecting the battery if possible.

**IMPORTANT!** *Many airbag systems will display a diagnostic code through their warning light after they lose power. Disconnecting the battery requires this code to be erased, a procedure that can require a trip to the dealer.*

## Deciding on component locations

### Locations for the siren

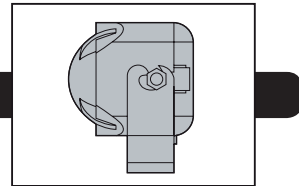

#### Some things to remember about mounting the siren:

- Keep it away from heat sources, such as radiators, exhaust manifolds, turbochargers and heat shields.
- Mount it where a thief cannot easily disconnect it, whether the bonnet is open or shut. Both the siren and its wires should be difficult to find. This usually involves disguising the wire to look like a factory harness.
- When possible, place the siren on the same side of the vehicle as the control module, where its wires will reach the control module's wires without extending them. Always run the wires through the centre of a grommet, never through bare metal!
- Point the siren down so water does not collect in it.

## Locations for the control box

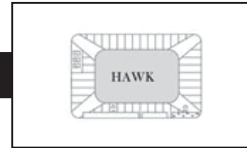

### Some things to remember about where to mount the control module:

- Never put the control module in the engine compartment!
- The first step in hot wiring a vehicle is removing the driver's side under-dash panel to access the starter and ignition wires. If the control module is placed just behind the driver's side dash it can easily be disconnected.
- When mounting the control module, try to find a secure location that will not require you to extend the harness wires. Keep it away from the heater core (or any other heat sources) and any obvious leaks.
- The higher the control module is in the vehicle, the better the transmitter range will be. If you put the control module under a seat or inside a metal dashboard, range will suffer.
- Some good control module locations: above the glove box, inside the centre console, above the under-dash fuse box, above the radio etc.

## Locations for the status LED

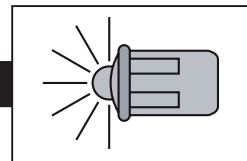

### Some things to remember when positioning the status LED:

- It should be visible from both sides and the rear of the vehicle, if possible.
- It needs at least 1/2 inch clearance to the rear.
- It is easiest to use a small removable panel, such as a switch blank or a dash bezel. Remove it before drilling your 1/2 inch hole.

## Locations for the Hawkguard shock sensor

### Some things to remember about where to mount the shock sensor:

- Never put the shock sensor in the engine compartment!
- Find a spot close to the control module so that the wires do not need to be extended. Keep it away from the heater core (or any other heat sources) and any obvious leaks.

### How the shock sensor is mounted is the most important factor in its performance. We recommend 2 methods:

- Using double-sided tape or hook-and-loop fastener to mount to a trim panel or an air duct, or
- Wire-tying to a wire harness.

## Locations for the Hawkguard ultra sonic sensors

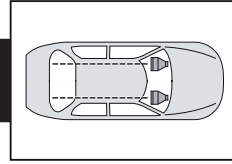

Ultrasonic cells should be placed on the left and right side as high as possible so to obtain the best performance.

Inappropriate adjustment for the Ultrasonic sensor may let to a false alarm. To prevent the false alarm, make sure the sensibility of ultrasonic sensor is in an appropriate degree. An over adjustment is usually the main reason to cause false alarm.

## Locations for the immobiliser relay

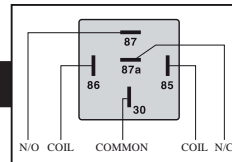

If Immobiliser relay or its connections are immediately visible upon removal of the under-dash panel, they can easily be bypassed. Always make the relay and its connections difficult to discern from the factory wiring! Exposed yellow butt connectors do not look like factory parts, and will not fool anyone! For this reason, routing the immobiliser relay wires away from the steering column is recommended.

## Finding the wires you need

Now that you have decided where each component will be located, you're going to find the wires in the car that the security system will be connected to:

**IMPORTANT!** *Do not use a 12v test light to find these wires! Use a digital multi-meter for all testing.*

## Obtaining constant 12 volts

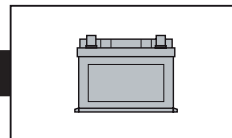

We recommend two possible sources for 12v constant: the (+) terminal of the battery, or the constant supply to the ignition switch. Always install a fuse within 12 inches of this connection. If the fuse also will be powering other circuits, such as door locks, a power window module, headlight control system etc, fuse accordingly.

## Finding the 12v switched ignition wire

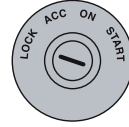

The ignition wire is powered when the key is in the run or start position. This is because the ignition wire powers the ignition system (spark plugs, coil) as well as the fuel delivery (fuel pump, fuel injection computer). Accessory wires lose power when the key is in the start position to make current available to the starter motor.

### How to find (+) 12v ignition with your multi-meter:

1. Set to DCV or DC voltage (12v or 20v is fine).
2. Attach the (-) probe of the meter to chassis ground.
3. Probe the wire you suspect of being the ignition wire. The steering column harness or ignition switch harness is an excellent place to find this wire.
4. Turn the ignition key switch to the run position. if your meter reads (+)12v, go to the next step. If it doesn't, probe another wire.
5. Now turn the key to the start position. the meter display should stay steady, not dropping more than a few tenths of a volt. If it drops close to or all the way to zero, go back to Step 3. If it stays steady at (+) 12v, you have found an ignition wire.

## How to find starter wires 12 volts ONLY in crank position

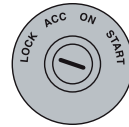

Testing a starter wire is very simple. Start by locating the suspected wire in the vehicle. Next, take your meter's black lead and connect it to ground. Next, connect the red lead to the wire you believe is the starter wire. Crank the vehicle. The meter should ONLY show 12v when the key is in the crank position. There should be 0 volts in all other positions. Starter wires are used in Remote Car Starter Installations.

Using the above testing guidelines, you can test any wire. When testing an accessory like a horn or interior light in the vehicle, simply activate the accessory with your meter leads in place to get the meter reading. The meter should only read power and ground on accessory items when they are activated.

## Finding the door pin switch circuit

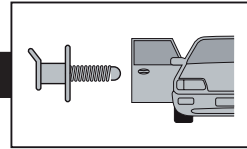

### The best places to find the door switch wire are:

- At the pin switch: when testing the pin switch, check wire to ensure that it 'sees' all the doors. Often, the passenger switch will cover all the doors even if the driver's switch will not.
- At the interior light: this may not be your best choice if the vehicle has delayed interior light supervision, but it will work in many Hondas, or any vehicle with completely diode-isolated pin switches.
- Once you have determined the wire colour, the easiest place to connect to the wire is often at the kick panel, at the windscreen pillar, or in the running board. When an easy location is not available, running a wire to the interior light itself is often the best solution.

### How to find a door pin switch trigger wire with multi-meter:

1. Set to DCV or DC voltage (12v or 20v is fine).
2. In most Fords, fasten the (-) probe of the meter to chassis ground. In most other cars, fasten the (+) probe of your meter to (+) 12v constant.
3. Probe the wire you suspect of being the door trigger wire. If the meter reads (+) 12v when any door is opened, you have found a trigger wire.

## Making your wiring connections

There are two acceptable ways of making a wire connection – solder connections and crimp connectors. When properly performed, either type of connection is reliable and trouble-free. Regardless of whether you solder your connections or you use mechanical-type crimp on connections are mechanically sound and that they are insulated. Cheap electrical tape, especially when poorly applied, is not a reliable insulator. It often falls off in hot weather. Use good quality electrical tape or heat shrink.

- Never twist-and-tape the wires together without soldering.
- Never use 'fuse taps' as the can damage fuse box terminals.

## Primary harness wire connection guide C1-12 pin connector

This guide describes in detail the connection of each wire. Also included are possible applications of each wire. This system was designed with the ultimate in flexibility and security in mind. Please read the instructions carefully to ensure a thorough understanding and how it operates; also see wiring diagram of HA-280 PRO.

### **BLUE WIRE:**

Negative Door Input (-). Connect to the Driver door pin switch circuit wire that shows ground (-) when the door is open.

**Note:** Nearly all cars have negative door input. Consult owner manual for polarity.

### **GREEN WIRE:**

Positive Door Input (+). Connect to the driver door pin switch circuit wire that shows +12v when the door is open.

**Note:** Consult owner manual for polarity.

### **GREY WIRE:**

Negative Hand Brake Input (-). Connect to the hand brake. If the hand brake is not in pull position, remote engine start will not function.

### **BROWN WIRE:**

Positive Hazard Light Output (+). Connect the brown wire to the circuit that shows +12v or only when the hazard lights are on. Right hazard light.

### **BROWN WIRE:**

Positive Hazard Light Output (+). Connect the brown wire to the circuit that shows +12v or only when the hazard lights are on. Left hazard light.

### **WHITE WIRE:**

Positive Siren Output (+). Connect the white wire to the siren of white wire.

### **WHITE/BLACK WIRE:**

Positive Input (+). Connect the white/black wire to ignition positive when engine on. This signal is used as to confirm whether engine started, can connect to the tachometer line, or oil light or charging battery line.

### **BLUE/WHITE WIRE:**

Positive Input (+). Connect the blue/white wire that shows +12v when pressing the foot brake.

### **RED/BLACK WIRE:**

Negative Output (-). 250mA Interior Light. Connect to the wire that activates the vehicle's interior light.

**NOTE: MUST USE RELAY (not supplied).**

### **PINK WIRE:**

Negative Output (-). 250mA Boot Release. Connect to the boot release motor.

**NOTE: MUST USE RELAY (not supplied).**

### **YELLOW WIRE:**

Negative Output (-) 250mA Immobiliser. Connect to yellow wire to immobiliser relay.

### **RED WIRE:**

Negative Output (-). 250mA Window Closer. 30 second negative output.

**NOTE: MUST USE window closer module HA-64U (optional extra).**



## Secondary harness wire connection guide 6 pin connector – C2

### **BLACK WIRE:**

Ground Input (-). The black wire must connect to a solid chassis ground. Clean away any paint or dirt to ensure the best possible ground.

### **BLUE WIRE:**

Second Ignition Output (+). The blue wire provides +12v for second ignition wire.

### **YELLOW WIRE:**

Ignition Output (+). Connect to the main ignition wire that provides +12v when the ignition is on and while cranking the starter. Also, when ignition is off, this wire should not show any voltage (0v).

### **GREEN WIRE:**

Starter Output (+). Connect to the vehicle's starter wire.

### **RED WIRE:**

Main Power Input (+). Connect to the battery or constant power wire at the ignition switch with a minimum 25 amp supply.

### **WHITE WIRE:**

Accessory Output (+). Connect to the accessory wire coming from the ignition switch that supplies power to the heater/air conditioner.

## Immobiliser relay connection guide

### **YELLOW WIRE:**

Connect to yellow wire of alarm system C1 connector (pin 11).

### **WHITE WIRE:**

Connect to first accessory of ignition switch (+12v).

### **2 x GREEN WIRES:**

Normally closed, can be connected to starter motor, positive side of coil, for diesel car fuel pump. See wiring diagram for guidance.

# WIRING DIAGRAM

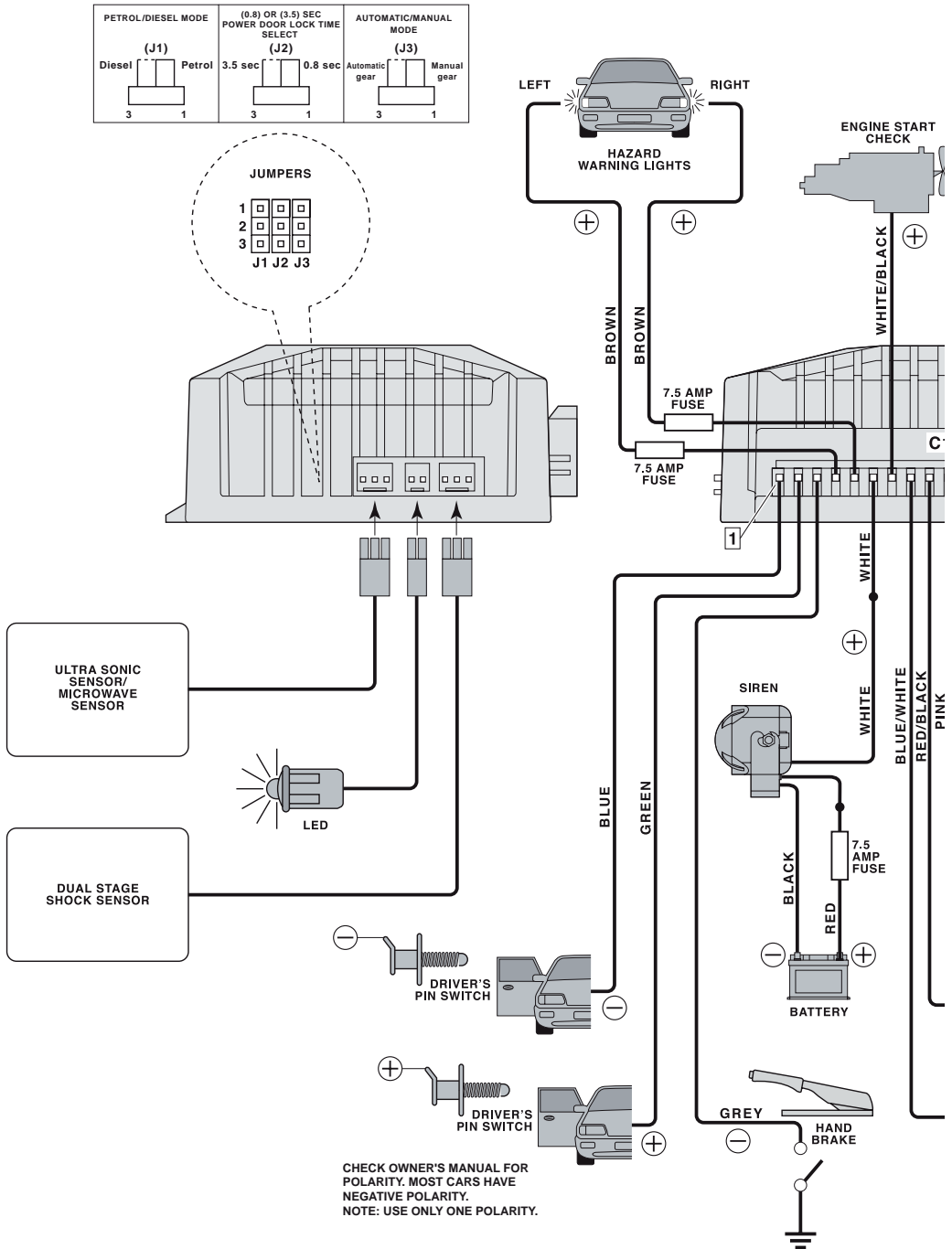

# AM HA-280 PRO

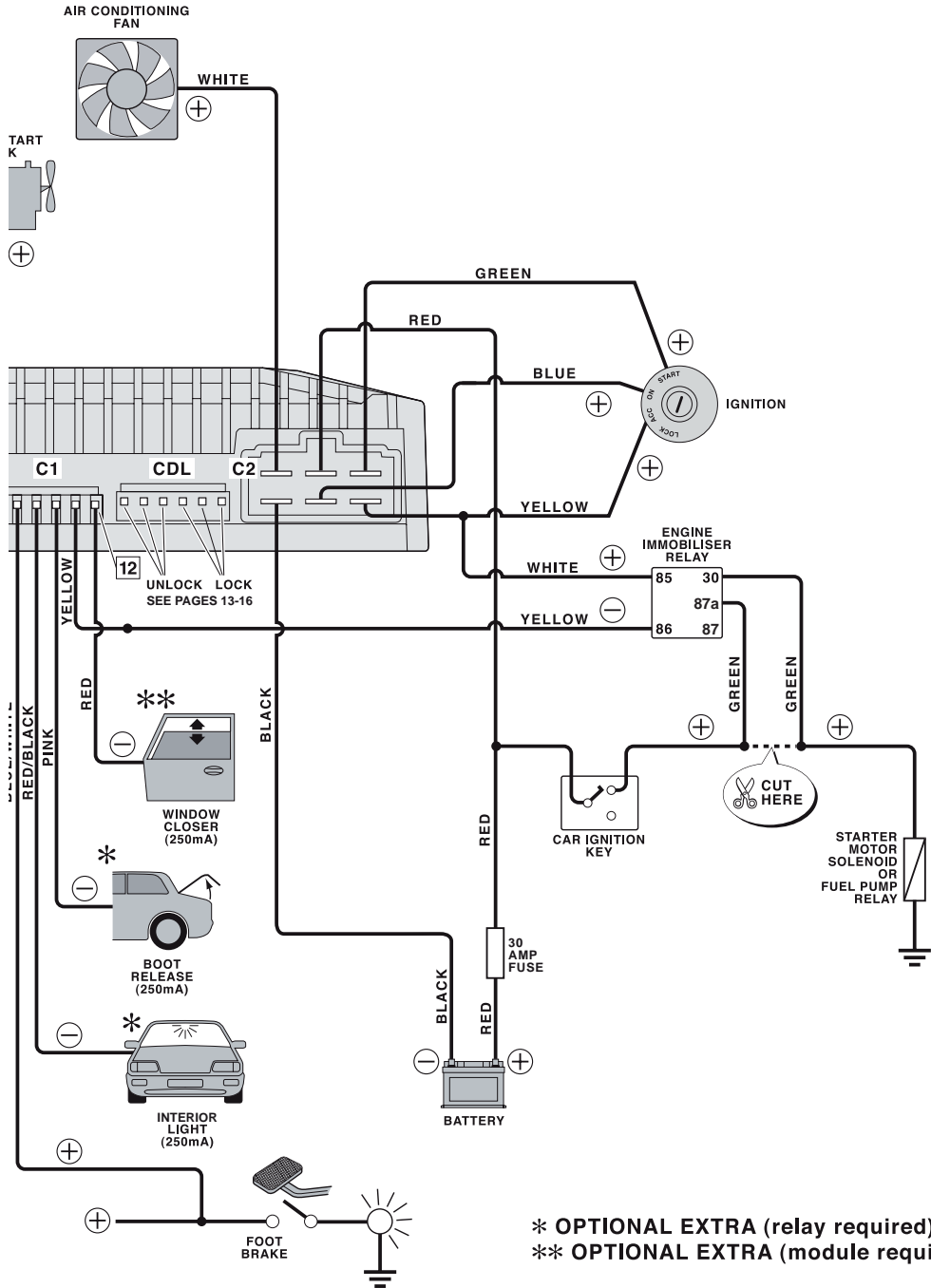

\* OPTIONAL EXTRA (relay required)  
 \*\* OPTIONAL EXTRA (module required)

## Siren connection guide

### RED WIRE:

Connect to battery direct or constant 12v power supply.

**Note:** Use 7.5 amp fuse (not supplied).

### BLACK WIRE:

Ground Input (-). The black wire must connect to a solid chassis ground. Clean away any paint or dirt to ensure the best possible ground.

### WHITE WIRE:

Connect to white cable of alarm C1 connector (pin 6).

## Jumpers setup

The illustration shows how the jumpers are set up. When the jumper cap is placed on the pins, the jumper is 'SHORT'. If no jumper cap is placed on the pins, the jumper is 'OPEN'. The illustration shows a 3-pin jumper whose pin 1 and pin 2 are 'SHORT' when jumper cap is placed on these 2 pins.

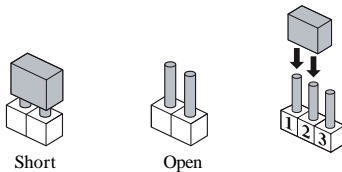

### J1 Petrol / Diesel Mode:

Short pin 1, pin 2 to enable petrol mode (factory default).



Short pin 2, pin 3 to enable diesel mode.



### J2 Central Door Locking Time Selector:

Short pin 1, pin 2 to enable 0.8 seconds (factory default).



Short pin 2, pin 3 to enable 3.5 seconds.



### J3 Automatic / Manual Gear Mode:

Short pin 1, pin 2 to enable manual gear mode (factory default).



Short pin 2, pin 3 to enable automatic gear mode.



**ATTENTION:** Commercial Electronics always suggests installation be performed by a certified and trained installation technician, professional installation is a requirement to obtain full warranty. This wiring information is being provided free of charge and on an 'as is' basis, without any representation or warranty to the products being installed. It is your responsibility to insure proper installation. Commercial Electronics assumes no responsibility with regards to the accuracy or currency of this information.

Proper installation in every case is and remains the responsibility of the installer. Commercial Electronics assumes no responsibility resulting from an improper installation, even in reliance upon this information. Any harm or injury to the installer is in no way the responsibility of Commercial Electronics. Any damage to the vehicle during installation or after installation is not the responsibility of Commercial Electronics.

# Central locking technical diagrams

### Diagram A Negative locking

PRIOR TO MAKING THE CONNECTION ENSURE  
THE ALARM IS PROGRAMMED FOR THE  
APPROPRIATE LOCKING PULSE

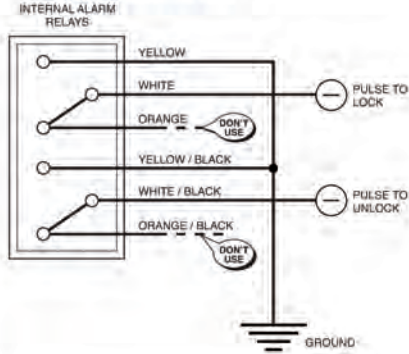

### Diagram C Single point locking

PRIOR TO MAKING THE CONNECTION ENSURE  
THE ALARM IS PROGRAMMED FOR THE  
APPROPRIATE LOCKING PULSE

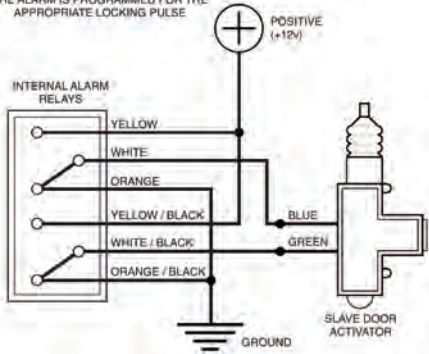

### Diagram B Positive locking

PRIOR TO MAKING THE CONNECTION ENSURE  
THE ALARM IS PROGRAMMED FOR THE  
APPROPRIATE LOCKING PULSE

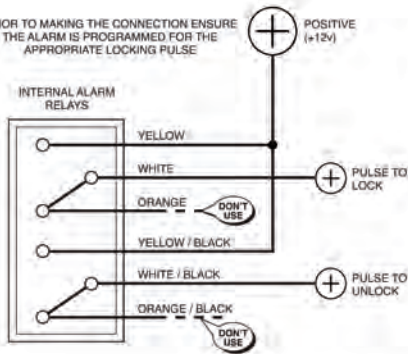

### Diagram D Vacuum locking

PRIOR TO MAKING THE CONNECTION ENSURE  
THE ALARM IS PROGRAMMED FOR THE  
APPROPRIATE 3 SECOND LOCKING/  
UNLOCKING PULSE

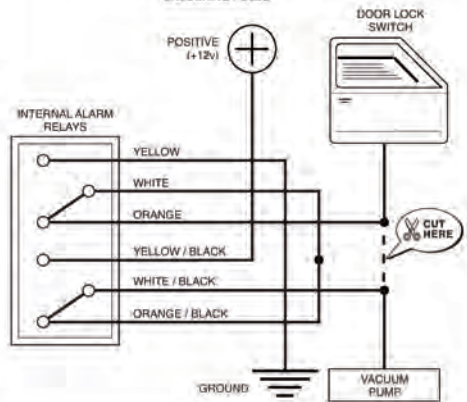

# Central locking technical diagrams

## Diagram E

### Actuator interrupt (negative at rest)

PRIOR TO MAKING THE CONNECTION ENSURE THE ALARM IS PROGRAMMED FOR THE APPROPRIATE LOCKING PULSE

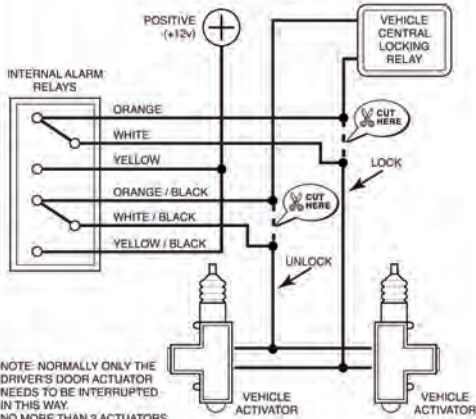

## Diagram G

### Positive locking with comfort closing

PRIOR TO MAKING THE CONNECTION ENSURE THE ALARM IS PROGRAMMED FOR THE APPROPRIATE LOCKING AND COMFORT CLOSING PULSE

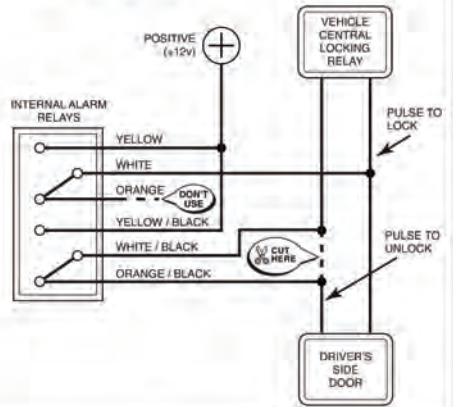

## Diagram F

### Negative locking with comfort closing

PRIOR TO MAKING THE CONNECTION ENSURE THE ALARM IS PROGRAMMED FOR THE APPROPRIATE LOCKING AND COMFORT CLOSING PULSES

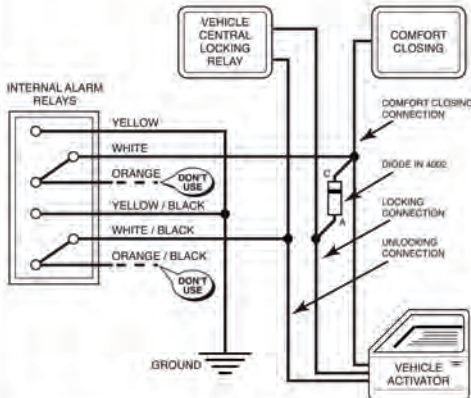

## Diagram H

### Single wire - negative to unlock, interrupted to lock

PRIOR TO MAKING THE CONNECTION ENSURE THE ALARM IS PROGRAMMED FOR THE APPROPRIATE LOCKING PULSE

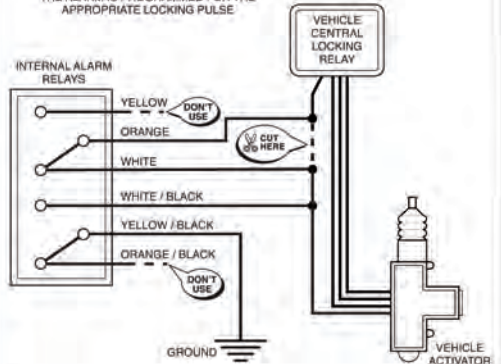

# Central locking technical diagrams

## Diagram I

**Single wire - negative to lock, interrupted to unlock**

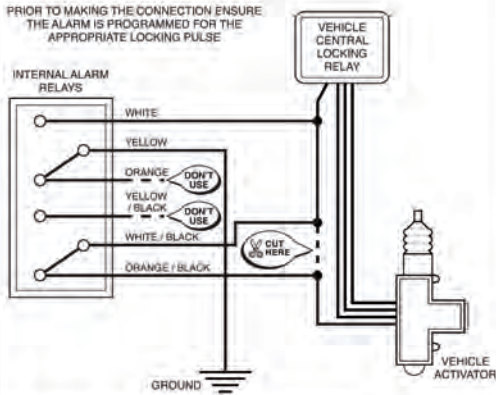

## Diagram M

**Central locking control resistive positive**

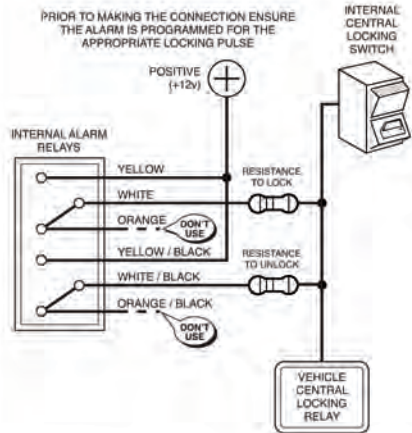

## Diagram L

**Central locking control resistive negative**

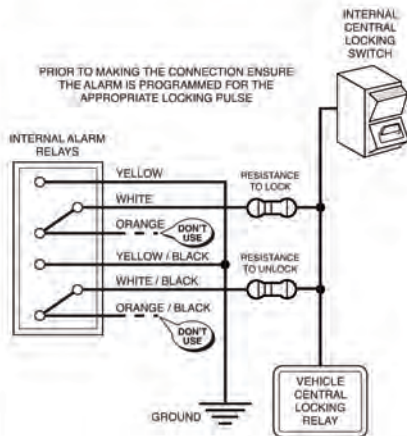

## Diagram N

**Central locking control resistive negative lock only**

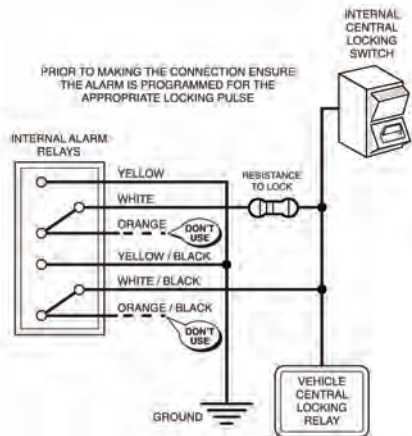

# Central locking technical diagrams

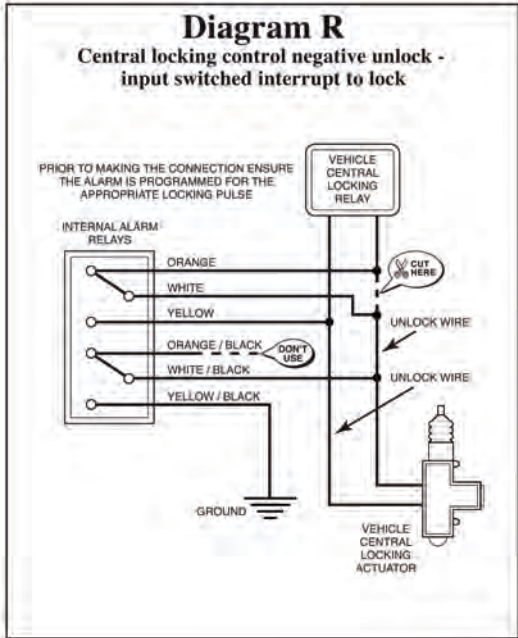
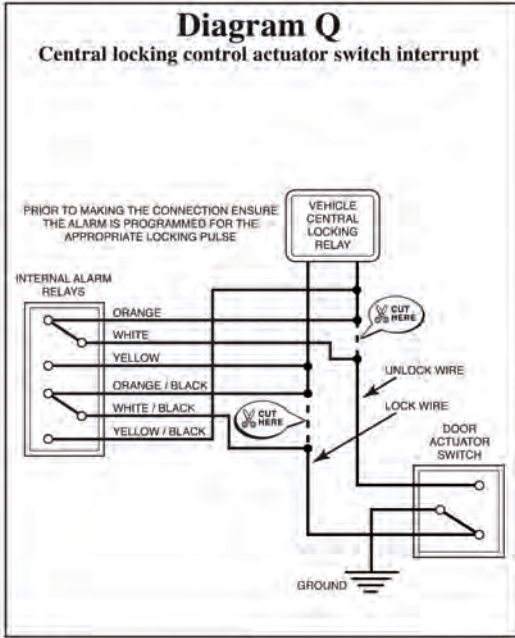
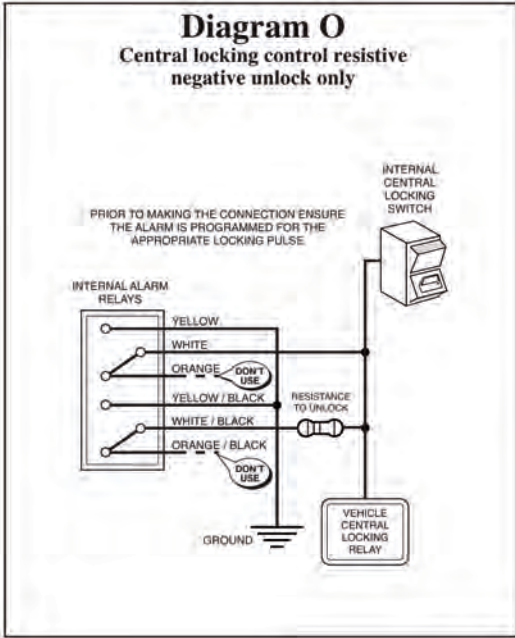



## Bonnet and door protection

Optional diode and bonnet pin switch not included

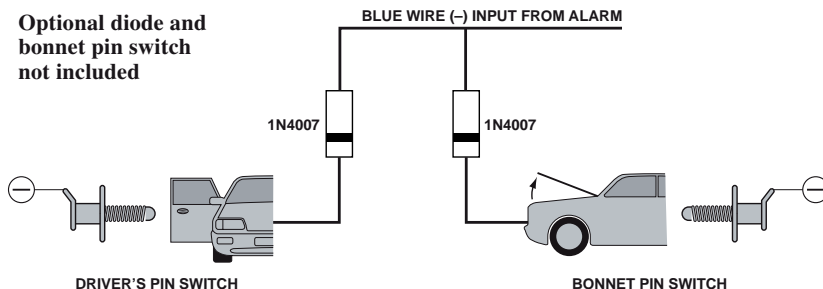

## Interior light supervision relays

For negative interior light

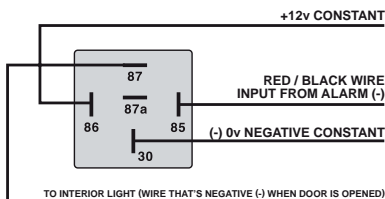

For positive interior light

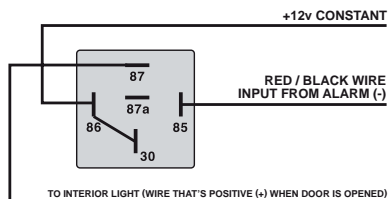

## Boot release configurations

Optional extra

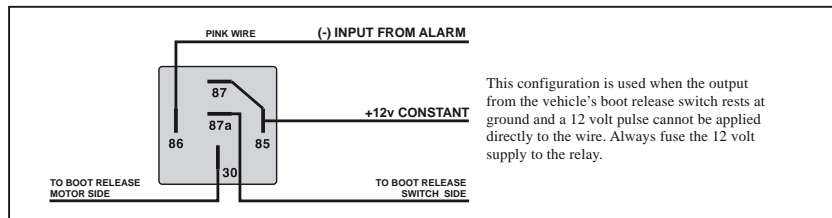
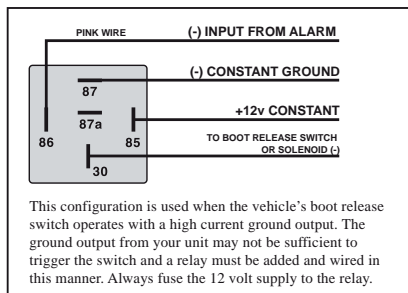
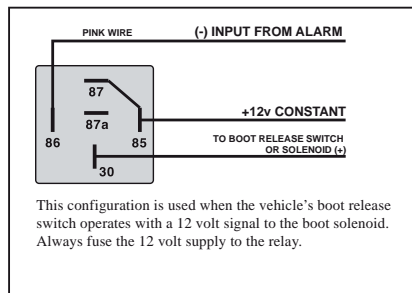



# Consumer Warranty

Commercial Electronics ("HAWK®") promises to the original purchaser to repair or replace with a comparable reconditioned model any HAWK unit (hereafter the "unit"), excluding without limitation the siren, the remote transmitters, the associated sensors and accessories, which proves to be defective in workmanship or material under reasonable use during one year from date of purchase, provided the following conditions are met: the unit was professionally installed and serviced by an authorised HAWK dealer; the unit will be professionally reinstalled in the vehicle in which it was originally installed by an authorised HAWK dealer; and the unit is returned to HAWK, shipping prepaid with a legible copy of the bill of sale or other dated proof of purchase bearing the following information: consumer's name, telephone number and address; the authorised dealer's name, telephone number and address; complete product description, including accessories; the year, make and model of the vehicle; vehicle license number and vehicle identification number. All components other than the unit, including without limitation the siren, the remote transmitters and the associated sensors and accessories, carry a one-year warranty from the date of purchase of the same. This warranty is non-transferable altered, the unit has been modified or used in a manner contrary to its intended purpose; the unit has been damaged by accident, unreasonable use, neglect, improper service, installation or other causes not arising out of defects in materials or construction. The warranty does not cover damage to the unit caused by installation or removal of the unit. HAWK, in its sole discretion, will determine what constitutes excessive damage and may refuse the return of any unit with excessive damage.

**TO THE MAXIMUM EXTENT ALLOWED BY LAW, ALL WARRANTIES, INCLUDING BUT NOT LIMITED TO EXPRESS WARRANTY, IMPLIED WARRANTY, WARRANTY OF MERCHANTABILITY, FITNESS FOR PARTICULAR PURPOSE AND WARRANTY OF NON-INFRINGEMENT OF INTELLECTUAL PROPERTY, ARE EXPRESSLY EXCLUDED; AND HAWK NEITHER ASSUMES NOR AUTHORISES ANY PERSON OR ENTITY TO ASSUME FOR IT ANY DUTY, OBLIGATION OR LIABILITY IN CONNECTION WITH ITS PRODUCTS. HAWK DISCLAIMS AND HAS ABSOLUTELY NO LIABILITY FOR ANY AND ALL ACTS OF THIRD PARTIES INCLUDING ITS AUTHORISED DEALERS OR INSTALLERS. HAWK SECURITY SYSTEMS, INCLUDING THIS UNIT, ARE DETERRENTS AGAINST POSSIBLE THEFT. HAWK IS NOT OFFERING A GUARANTEE OR INSURANCE AGAINST VANDALISM, DAMAGE OR THEFT OF THE AUTOMOBILE, ITS PARTS OR CONTENTS; AND HEREBY EXPRESSLY DISCLAIMS ANY LIABILITY WHATSOEVER, INCLUDING WITHOUT LIMITATION, LIABILITY FOR THEFT, DAMAGE AND/OR VANDALISM. THIS WARRANTY DOES NOT COVER LABOUR COSTS FOR MAINTENANCE, REMOVAL OR REINSTALLATION OF THE UNIT OR ANY CONSEQUENTIAL DAMAGES OF ANY KIND. IN THE EVENT OF A CLAIM OR A DISPUTE INVOLVING HAWK OR ITS SUBSIDIARY, THE PROPER VENUE SHALL BE ENGLAND & WALES . THE MAXIMUM RECOVERY UNDER ANY CLAIM AGAINST HAWK SHALL BE STRICTLY LIMITED TO THE AUTHORISED HAWK DEALER'S PURCHASE PRICE OF THE UNIT. HAWK SHALL NOT BE RESPONSIBLE FOR ANY DAMAGES WHATSOEVER, INCLUDING BUT NOT LIMITED TO, ANY CONSEQUENTIAL DAMAGES, INCIDENTAL DAMAGES, DAMAGES FOR THE LOSS OF TIME, LOSS OF EARNINGS, COMMERCIAL LOSS, LOSS OF ECONOMIC OPPORTUNITY AND THE LIKE. NOTWITHSTANDING THE ABOVE, THE MANUFACTURER DOES OFFER A LIMITED ONE YEAR WARRANTY TO REPLACE OR REPAIR THE CONTROL MODULE AS DESCRIBED ABOVE.**

Manufactured by Commercial Electronics Co. Ltd. Great Britain. © Commercial Electronics 2015.

