



# X90 v5

## User's Manual

### Guide to Intelligent Alarm Immobiliser



Designed and  
Engineered in the UK

Manufacturer:  
COMMERCIAL ELECTRONICS CO. LTD  
264 HAYDONS ROAD, WIMBLEDON, LONDON SW19 8TT. UK

TEL: +44 020 8404 7105 FAX: +44 020 84047104  
<http://www.hawkcaralarm.com> e-mail: [info@hawkcaralarm.com](mailto:info@hawkcaralarm.com)

# HA-X90 OWNER GUIDE



- |   |  |
|---|--|
|  Arm Alarm   |  Disarm alarm |
|  Bike Finder |  Remote start |

Congratulations on the purchase of your state of the art Motorcycle / Scooter security system. This system has been designed to provide years of trouble-free operation.

HA- X90 Pro v5 is a reliable Motorcycle / Scooter alarm system, which provides 2 designs to prevent thieving. The first design is to use the loud siren. When any illegal intrusion happens, the siren will sound loudly to warn the intruder. The second design is to use an immobilisation system to disable the engine start.

This owner's guide should help you to get the most out of your system. Please take the time to read it prior to using the system.

HAWK HA-X90 Pro system consists of the following main components:

- Two military grade encrypted LCD Remote transmitters
- Main unit with remote start
- Dual zone HAWKGUARD shock sensor
- Built in Tilt Sensor
- LED



# HA-X90 OWNER GUIDE

- Built in engine immobiliser relay
- 125db siren
- 1 x HAWK sticker
- Universal Wiring Harness

**Important:** When installing a Hawk Alarm to any vehicle fitted with LED indicators (turn signals) it is responsibility of the installer to verify the indicators are powered by DC 12v & not CANBUS controlled. If there is any doubt this DO NOT connect the indicators otherwise irreversible component damage may occur. Commercial Electronics Co Ltd accepts no responsibility for any damage caused by incorrectly chosen wiring connections.



# ARMING THE ALARM SYSTEM

## NORMAL ARMING MODE

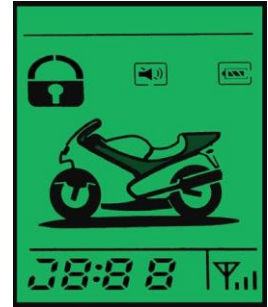
To arm the alarm system, turn the ignition switch OFF, press the  button, indicators will flash once; with single audible bleep LED starts to flash and LCD remote fob will bleep once, the alarm system will enter into the arming status after 5 seconds. LCD remote fob will show  icon on the screen. If motorcycle is slightly moved, the alarm will chirp and the indicator will flash lights 5 times, LCD remote fob hammer icon will flash and vibrate. If it's moved hard after 10 seconds then full reaction will occur and sound for 30 seconds. Engine will be completely immobilised and can not be driven away.





## SILENT ARMING/DISARMING

Press the  button twice, the lights will flash once LCD remote fob will bleep with  icon appear on LCD screen and the system will be armed.



## DISARMING THE ALARM SYSTEM

To disarm the alarm system, press the  button, indicators flash twice with two audible beeps. LCD remote will bleep twice and  icon will appear on the screen to confirm.

Note: In silent arm status, the siren will not bleep.

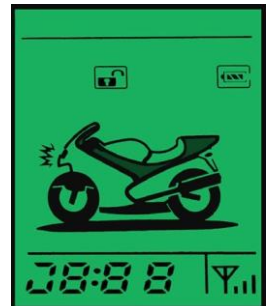

## ARMING REMINDER

When the Motorcycle is parked and owner left the Motorcycle after 8 seconds, system will sound siren 3 times and flash indicator lights 3 times, LCD remote will bleep , lock icon will flash and vibrate to remind owner to arm the security system.

## AUTO- REARM

During arm mode, if  button pressed and engine not started within 25 seconds system will re-arm automatically and LCD remote fob will sound “Du” and vibrate (silent arm mode, siren will not sound).

## EMERGENCY KEY RESET:

### Enable Emergency Key Reset:

If the remote control is lost the owner can disarm with the key. Please refer to steps below:

Turn the ignition from OFF to ON 10 times repeatedly, leaving last sequence to Ignition ON at least 2 seconds. System will disarm automatically.

### To Exit Emergency Key Reset:

Press the  button on LCD remote fob to exit emergency disarm mode. Also code learning mode will exit emergency key reset mode.

## TILT / SHOCK SENSOR WARNING

During 1<sup>st</sup> stage shock sensor triggered during alarm mode, the siren sound 5 times and indicator lights will flash 5 times. Engine will be immobilise immediately.

LCD remote fob will bleep 5 times. Remote fob will vibrate with flashing of Icons (shock and headlight icon). This will be done only once.





During 2<sup>nd</sup> stage (full alarm mode) if alarm is triggered within 10 seconds after 1st stage. Then system will go into full alarm mode. Siren will activate for 30 seconds and indicator lights flash for 30 seconds and engine will be immobilise.

LCD remote fob will bleep for 30 seconds. Remote fob will vibrate 8 times. Flashing of Icons (shock and headlight icon) will appear on LCD screen. After 30 seconds system will automatically re arm.

In silent arming mode, siren will not sound.

### **BIKE FINDER/PANIC**

Press  button once with the ignition in OFF position and the indicator lights will flash for 10 seconds and siren will bleep for 10 seconds. Press  button to exit bike finder mode.

### **SILENT BIKE FINDER/PANIC**

Press and hold  button, indicator lights will flash continuously without bleeping siren. Press any button to exit bike finder mode.

## REMOTE START



### Read Warning! Safety First

Press the  button twice within three seconds, Remote engine icon will appear on LCD remote fob, LCD remote fob will beep for 3 times, engine will start automatically, and used for non-key driving and warm-up. Repeat the above operation if the engine does not function due to cold weather or due to slow rotation of engine. Engine will stay on 10 minutes.

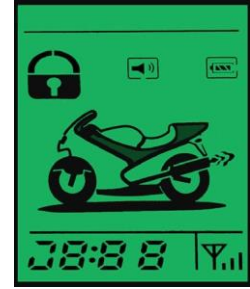

**How to turn off the remote start function:** press the  button once then engine will stop.



### Warning! Safety first

When properly installed, this system can start the bike via a command signal from the remote control transmitter.

Therefore, never operate the system in an enclosed area or partially enclosed area without ventilation (such as a garage). It is the user's sole responsibility to properly handle and keep out of reach from children all remote control transmitters to assure that the system does not unintentionally remote start the bike. **THE USER MUST INSTALL A CARBON MONOXIDE DETECTOR IN OR ABOUT THE LIVING AREA ADJACENT TO THE VEHICLE. ALL DOORS LEADING FROM ADJACENT LIVING AREAS TO THE ENCLOSED OR PARTIALLY ENCLOSED VEHICLE STORAGE AREA MUST AT ALL TIMES REMAIN CLOSED.** These precautions are the sole responsibility of the user.

Use of this product in a manner contrary to its intended mode of operation may result in property damage, personal injury, or death. (1) Never remotely start the bike with the bike in gear, and (2) Never remotely start the bike with the keys in the ignition.



The user must also have the neutral Safety feature of the bike periodically checked, wherein the bike must not remotely start while the bike is in gear. If the bike starts in gear, cease remote start operation immediately and consult with the authorized dealer to fix the problem.

**OPERATION OF THE REMOTE START MODULE IF THE VEHICLE STARTS IN GEAR IS CONTRARY TO ITS INTENDED MODE OF OPERATION. OPERATING THE REMOTE START SYSTEM UNDER THESE CONDITIONS MAY RESULT IN PROPERTY DAMAGE OR PERSONAL INJURY. YOU MUST IMMEDIATELY CEASE THE USE OF THE UNIT AND SEEK THE ASSISTANCE OF AN AUTHORIZED DEALER TO REPAIR OR DISCONNECT THE INSTALLED REMOTE START MODULE. HAWK CAR ALARM WILL NOT BE HELD RESPONSIBLE OR PAY FOR INSTALLATION OR REINSTALLATION COSTS.**

### **ANTI HOTWIRE**

When system in armed mode if system detects the ignition is forcibly switched on (hotwired) siren will activate and indicator lights will flash, the engine is automatically immobilised and motorcycle cannot be started up. Siren and indicator lights will flash for 30 seconds. On LCD remote fob will bleep for 30 seconds and “Exhaust pipe and headlight Icons will appear on LCD screen. LCD remote fob will vibrate 8 times and system will rearm again.

### **ANTI HIJACK**

Press and hold the  button for 2 seconds at the same time when ignition is on engine will immobilise within 20 seconds, siren will sound continuously and indicator lights will flash continuously. Press the  button to deactivate anti hijack mode.

### **SIREN SILENCING DURING ARM**

When the siren has been triggered, siren can be turned off without switching off the alarm. Press  button once during siren sounding duration.



## ADJUSTING SHOCK SENSOR

Remove dust cover from side of alarm main control box. Adjust shock sensor sensitivity with screw driver according to user need.

## LED FUNCTION / ALARM MEMORY:

In arm mode LED will flash twice within interval of 2 seconds. This will indicate alarm is on arm mode.

If system triggered by shock sensor LED will flash continuously for 30 seconds then the LED will flash 4 times within interval of 4 seconds until the system is disarmed.

If the system is triggered by ignition on (anti-hotwire), the LED will flash continuously until system is disarmed and Ignition turned on.

## MEMORY FUNCTION

During the alert state, if the alarm is detached from the cable harness, when restored it will “remember” the state in which was, preventing in this way every attempt of tampering.

## LEARNING TRANSMITTER CODES: (We have already done this for you!!!)

The included transmitters are pre programmed into the systems memory at the factory. Follow the below steps to add or delete a new transmitter.

1. In disarming mode, Ignition OFF position. Open the main control box. Press and hold the Micro switch. Press any button of 1<sup>st</sup> LCD remote fob. LED will flash twice and siren will bleep twice. The first remote fob will respond with Musical note indicating code learned successfully.
2. Within 8 seconds press any button of 2<sup>nd</sup> LCD remote fob, LED will flash four times and siren will bleep four times. The second remote fob will respond with Musical note indicating code learned successfully.
3. To exit code learning mode, release Micro switch and close the control box.



Warning: After entering into code-learning mode, the previous remote codes will not be cleared. To clear the previous remote codes (In case remotes were lost), learn a new remote for at least 4 times, it will automatically replace all other remotes.

## LCD REMOTE FOB RADIO SIGNAL STRENGTH INDICATOR



In arm mode if no radio signal bar shown on LCD remote fob then alarm is out of range of main control box. If on the other hand radio signal bar shown on LCD remote fob then remote fob is communicating with main alarm unit.

**Note:** Radio range based on line of sight, unobstructed testing in ideal conditions. Actual range will vary due to local conditions including but not limited to environment, terrain, physical obstructions, vehicle location and orientation interference and other possible impediments.





## LCD REMOTE FOB BATTERY STATUS INDICATOR

If battery power is low, remote fob will make “Di..Di..” sound when pressing any key. This will remind user to change battery. If battery icon start to blink then battery should be changed immediately, otherwise remote fob will not function.

## LCD REMOTE FOB TIME / ALARM SETTING

Press  and  button together for 1 second to enter time/alarm adjustment mode.

Press the  button to shift and set among the following icon: time/min → time/h → alarm on/off → alarm/min → alarm/h → quit. The icon will flash when selected.

Press the  button to set each function, press the  button to enter next function setting. When Quit icon flash, press the button  and  button for 1 second to save and quit. Press the  only to quite without saving.

---

**Technical Data**

Working frequency : 433.92 MHz  
Modulated way: FSK

Alarm unit:

Working voltage : 12V±3V  
Static current: <=3.5 mA  
Siren volume: 110~125Db  
Operation Temperature: -40c ~ +85c

## Consumer Warranty

Commercial Electronics Co Ltd (“HAWK®”) promises to the original purchaser to repair or replace with a comparable reconditioned model any HAWK unit (hereafter the “unit”), excluding without limitation the siren, the remote transmitters, the associated sensors and accessories, which proves to be defective in workmanship or material under reasonable use during one year from date of purchase, provided the following conditions are met: the unit was professionally installed and serviced by an authorized HAWK dealer; the unit will be professionally reinstalled in the vehicle in which it was originally installed by an authorized HAWK dealer; and the unit is returned to HAWK, shipping prepaid with a legible copy of the bill of sale or other dated proof of purchase bearing the following information: consumer’s name, telephone number and address; the authorized dealers name, telephone number and address; complete product description, including accessories; the year, make and model of the vehicle; vehicle license number and vehicle identification number. All components other than the unit, including without limitation the siren, the remote transmitters and the associated sensors and accessories, carry a one-year warranty from the date of purchase of the same. This warranty is non-transferable altered, the unit has been modified or used in a manner contrary to its intended purpose; the unit has been damaged by accident, unreasonable use, neglect, improper service, installation or other causes not arising out of defects in materials or construction. The warranty does not cover damage to the unit caused by installation or removal of the unit. HAWK, in its sole discretion, will determine what constitutes excessive damage and may refuse the return of any unit with excessive damage. TO THE MAXIMUM EXTENT ALLOWED BY LAW, ALL WARRANTIES, INCLUDING BUT NOT LIMITED TO EXPRESS WARRANTY, IMPLIED WARRANTY, WARRANTY OF MERCHANTABILITY, FITNESS FOR PARTICULAR PURPOSE AND WARRANTY OF NON-INFRINGEMENT OF INTELLECTUAL PROPERTY, ARE EXPRESSLY EXCLUDED; AND HAWK NEITHER ASSUMES NOR AUTHORIZES ANY PERSON OR ENTITY TO ASSUME FOR IT ANY DUTY, OBLIGATION OR LIABILITY IN CONNECTION WITH ITS PRODUCTS. HAWK DISCLAIMS AND HAS ABSOLUTELY NO LIABILITY FOR ANY AND ALL ACTS OF THIRD PARTIES INCLUDING ITS AUTHORIZED DEALERS OR INSTALLERS. HAWK SECURITY SYSTEMS, INCLUDING THIS UNIT, ARE DETERRENTS AGAINST POSSIBLE THEFT. HAWK IS NOT OFFERING A GUARANTEE OR INSURANCE AGAINST VANDALISM, DAMAGE OR THEFT OF THE AUTOMOBILE, ITS PARTS OR CONTENTS; AND HEREBY EXPRESSLY DISCLAIMS ANY LIABILITY WHATSOEVER, INCLUDING WITHOUT LIMITATION, LIABILITY FOR THEFT, DAMAGE AND/OR VANDALISM. THIS WARRANTY DOES NOT COVER LABOUR COSTS FOR MAINTENANCE, REMOVAL OR REINSTALLATION OF THE UNIT OR ANY CONSEQUENTIAL DAMAGES OF ANY KIND. IN THE EVENT OF A CLAIM OR A DISPUTE INVOLVING HAWK OR ITS SUBSIDIARY, THE PROPER VENUE SHALL BE ENGLAND & WALES. THE MAXIMUM RECOVERY UNDER ANY CLAIM AGAINST HAWK SHALL BE STRICTLY LIMITED TO THE AUTHORIZED HAWK DEALER’S PURCHASE PRICE OF THE UNIT. HAWK SHALL NOT BE RESPONSIBLE FOR ANY DAMAGES WHATSOEVER, INCLUDING BUT NOT LIMITED TO, ANY CONSEQUENTIAL DAMAGES, INCIDENTAL DAMAGES, DAMAGES FOR THE LOSS OF TIME, LOSS OF EARNINGS, COMMERCIAL LOSS, LOSS OF ECONOMIC OPPORTUNITY AND THE LIKE. NOT WITH STANDING THE ABOVE, THE MANUFACTURER DOES OFFER A LIMITED ONE YEAR WARRANTY TO REPLACE OR REPAIR THE CONTROL MODULE AS DESCRIBED ABOVE.